

# PCB with CNC

- [my vevor 3018 cnc](#)
- [reference](#)
- [fritzing](#)
- [online jscut guide](#)
- [online ncviewer](#)
- [online drill to gcode converter](#)
  
- TODO online [carbide3d](#)

CNC for PCB:

- 22000RPM
- V-Bit cutter 30 degree 0.2mm
- first pass 0.04mm
- second pass 0.07mm with more feed

## fritzing

Make electronic schema with fritzing

[autoroute.webm](http://autoroute.webm)

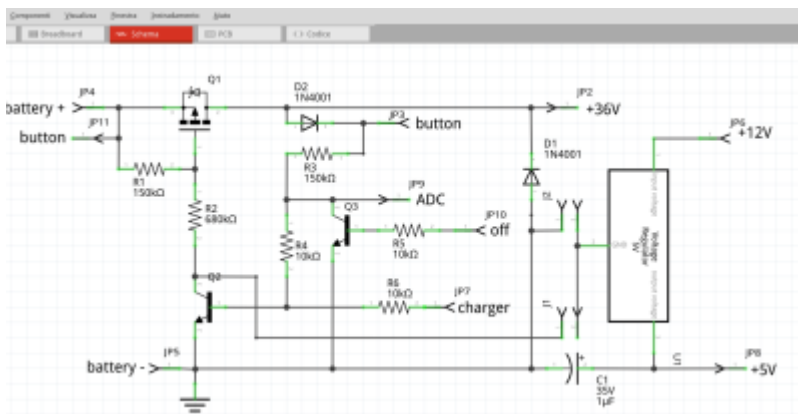

Make pcb routing:

- routing → DRC settings → 32mil large
- routing → DRC (check design at the end)

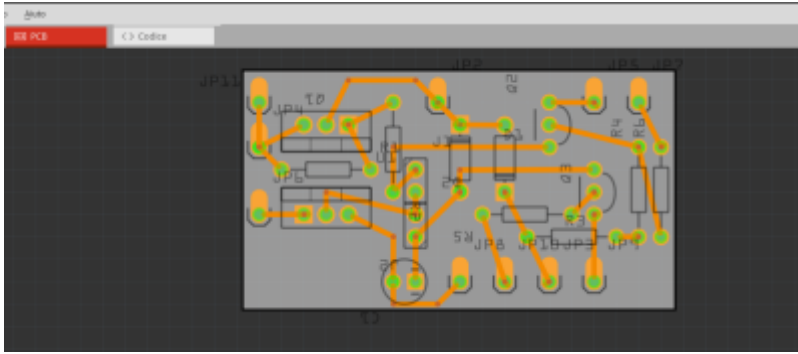

export gerber files

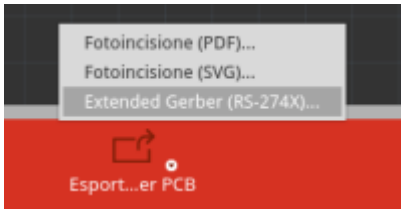

## flatcam

setup flatcam

[tools.webm](#)

new project

open files

[openfiles.webm](#)

bottom copper

[mirror.webm](#)

[bottom.webm](#)

top copper

[top.webm](#)

drill

[drill.webm](#)

contour

[contour.webm](#)

gcode spindle speed gradually

```
(splinde speed gradually to 15000rpm)
M03 S1000
G4 P0.5
M03 S2000
G4 P0.5
M03 S5000
G4 P0.5
M03 S7500
```

## deprecated

### convert gerber to svg

Upload <name>\_copperBottom.gbl to <https://tracespace.io>, select layers, download zip and extract <name>\_copperBottom.gbl



Now with inkscape we need to process the complex SVG with multiples path, objects, layers, group, etc. to convert it into a single path simple SVG. You need to open your SVG into Inkscape (Open-Source, cross-platform), and perform the following series of commands:

- CTRL+A (Select all),
- CTRL+U (Ungroup),
- CTRL+ALT+C (Convert stroke to path),
- CTRL+A (Select all),
- CTRL+U (Union) and
- CTRL+SHIFT+R (Fit page to content).
- CTRL+S save

### svg to gcode

Open [jscut](#):

- load SVG <name>\_copperBottom.gbl
- make all mm ([link](#))
- zero lower left ([link](#))
- select all objets, drills and path
- create operation
  - outside, 0.1mm
- generate
- save gcode

edit gcode to set spindle speed to 8000 rpm and turn on it clockwise (after G90)

```
; after first G1  
M3 S5000
```

## carbide3d

set spindle speed to 8000 rpm and turn on it clockwise (after G90)

```
G00 Z1.000  
M3 S10000
```

substitute G01 F400 with G01 F40

substitute G00 Z3.000 with G00 Z1.000

deprecated

- export your PCB as .svg files by clicking on “Export for PCB” on the bottom. Click on the small arrow on the Export button and select “Etchable (SVG)”. You will get a bunch of svg's exported in your selected directory but we will only use two of them:
  - yourfilename\*\_etch\_copper\_bottom\_mirror.svg
  - yourfilename\*\_etch\_mask\_bottom\_mirror.svg

From:

<https://wiki.csgalileo.org/> - **Galileo Labs**

Permanent link:

<https://wiki.csgalileo.org/tips/pcb?rev=1620641329>

Last update: **2021/05/10 12:08**

